

# BUILDING HEIGHT

FLAT ROOF

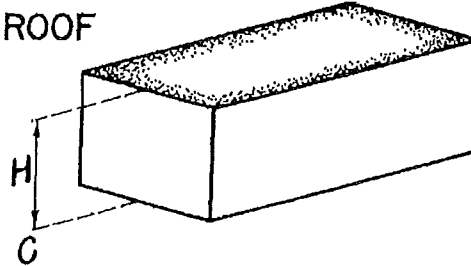

MANSARD ROOF

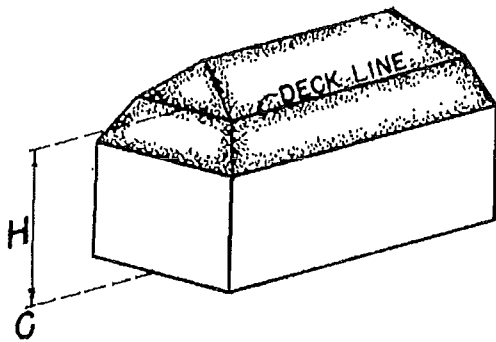

HIP ROOF

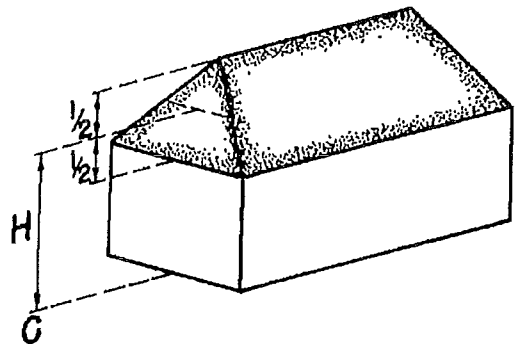

GAMBREL ROOF

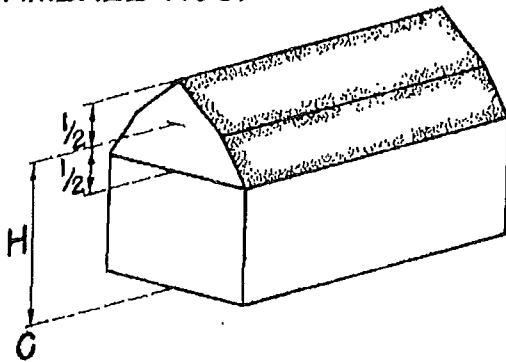

GABLE ROOF

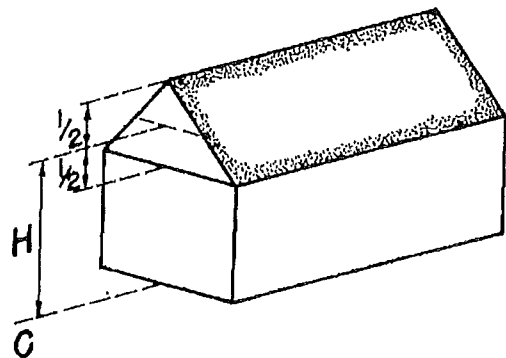

H=HEIGHT OF BUILDING

C=CURB LEVEL OR TENTATIVE CURB LEVEL GRADE

# LOT WIDTH AND LOT DEPTH EXPLAINED

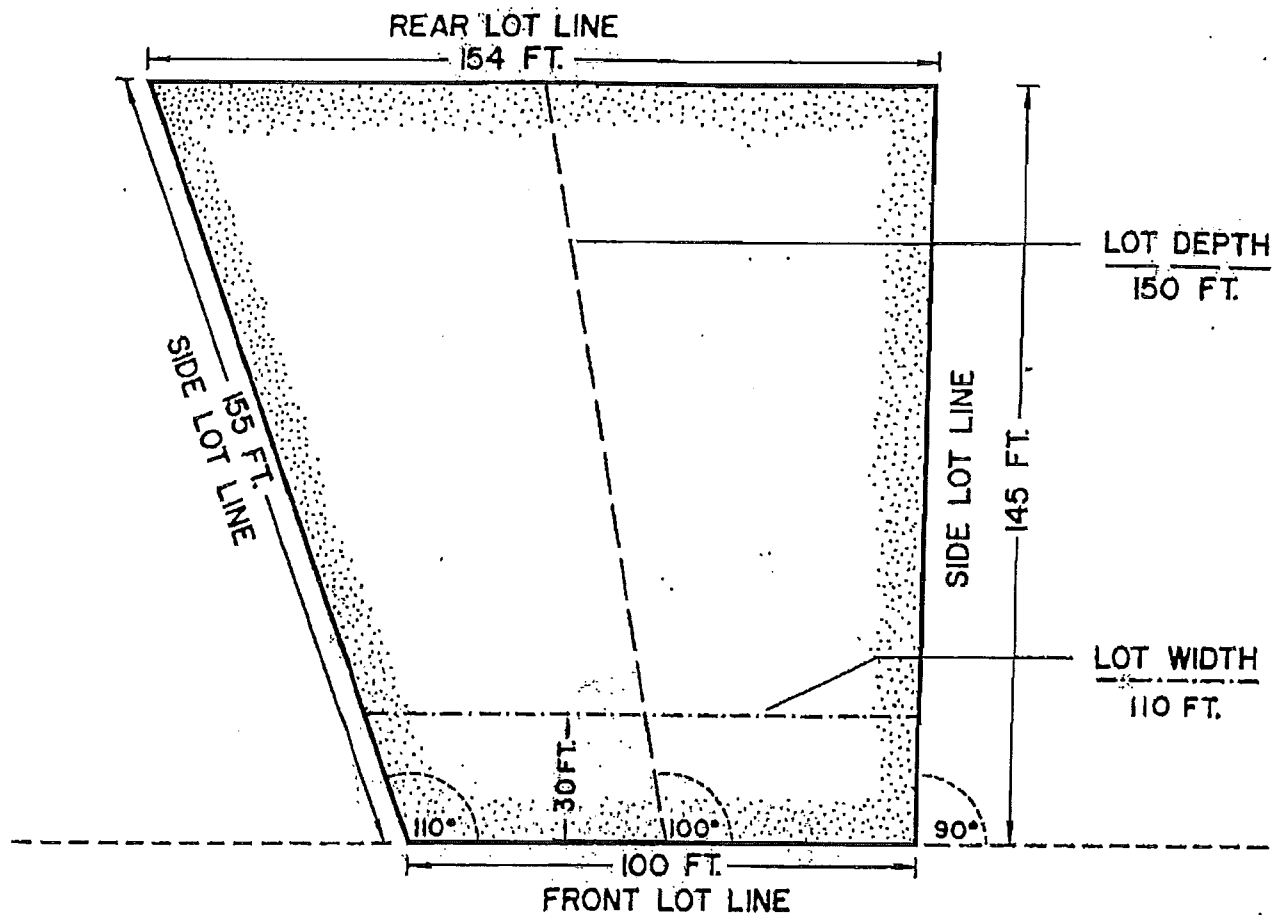

LOT WIDTH is the horizontal distance between the side lot lines of a lot, measured at the narrowest width within the first 30 feet of lot depth immediately in back of the front yard setback line.

LOT DEPTH is the mean horizontal distance between the front lot line and the rear lot line of a lot, measured within the lot boundaries.

# OFFSTREET PARKING - DESIGN REQUIREMENTS

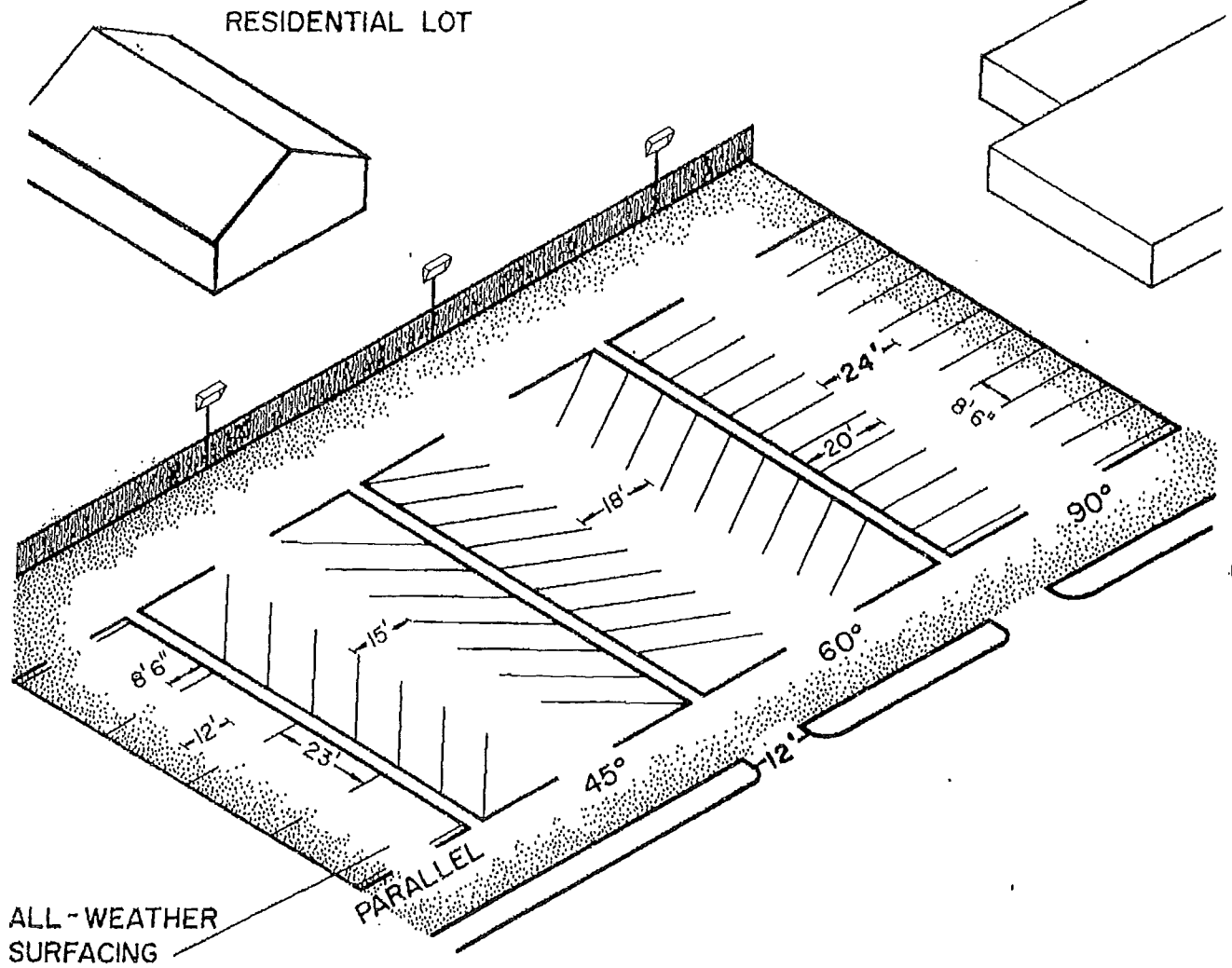

SCREENING FROM RESIDENCE -  
5 FEET MINIMUM  
LIGHTING DIRECTED INWARD

# RESIDENTIAL PLANNED DEVELOPMENT

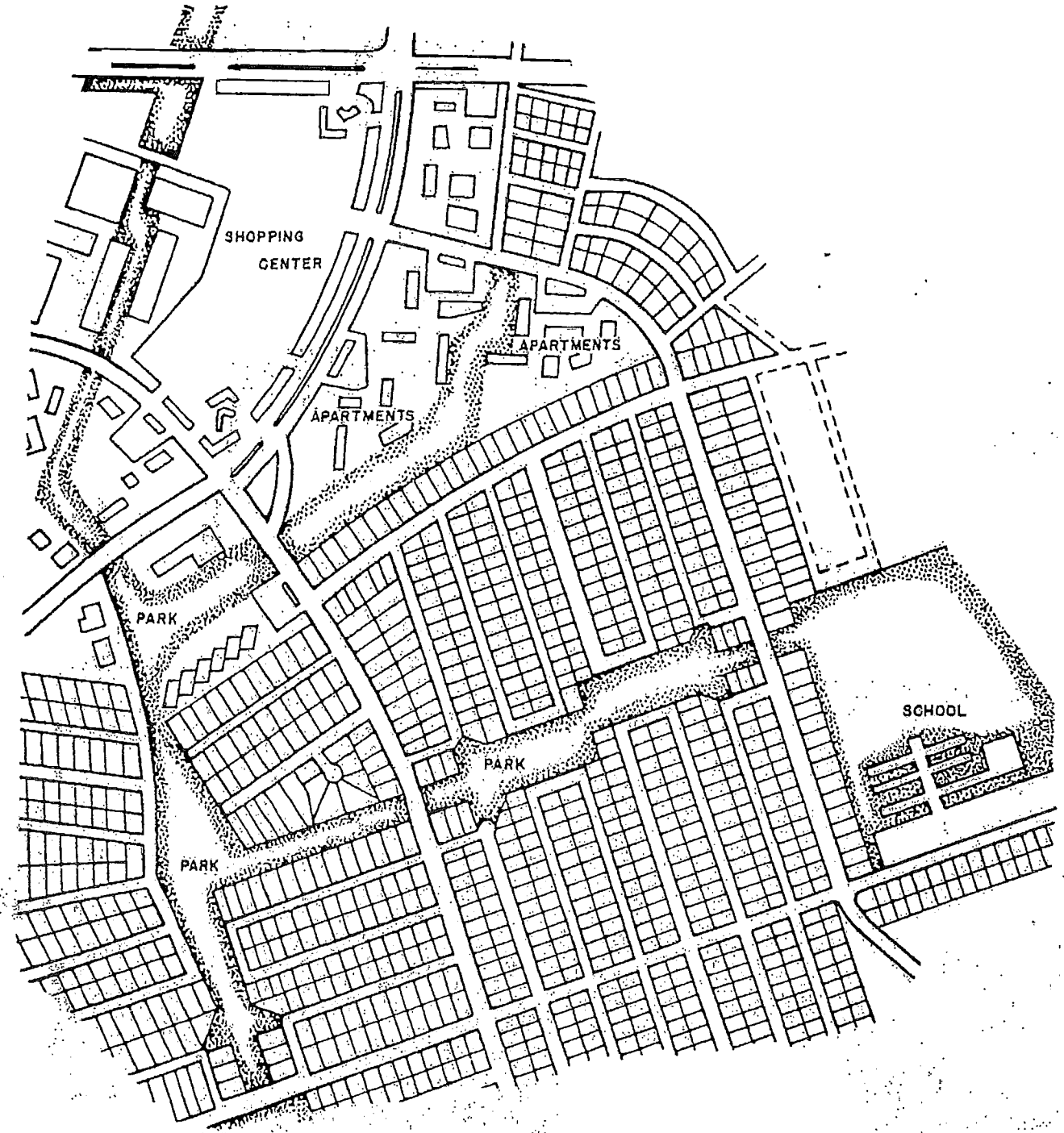

# REQUIRED YARDS -- ILLUSTRATED

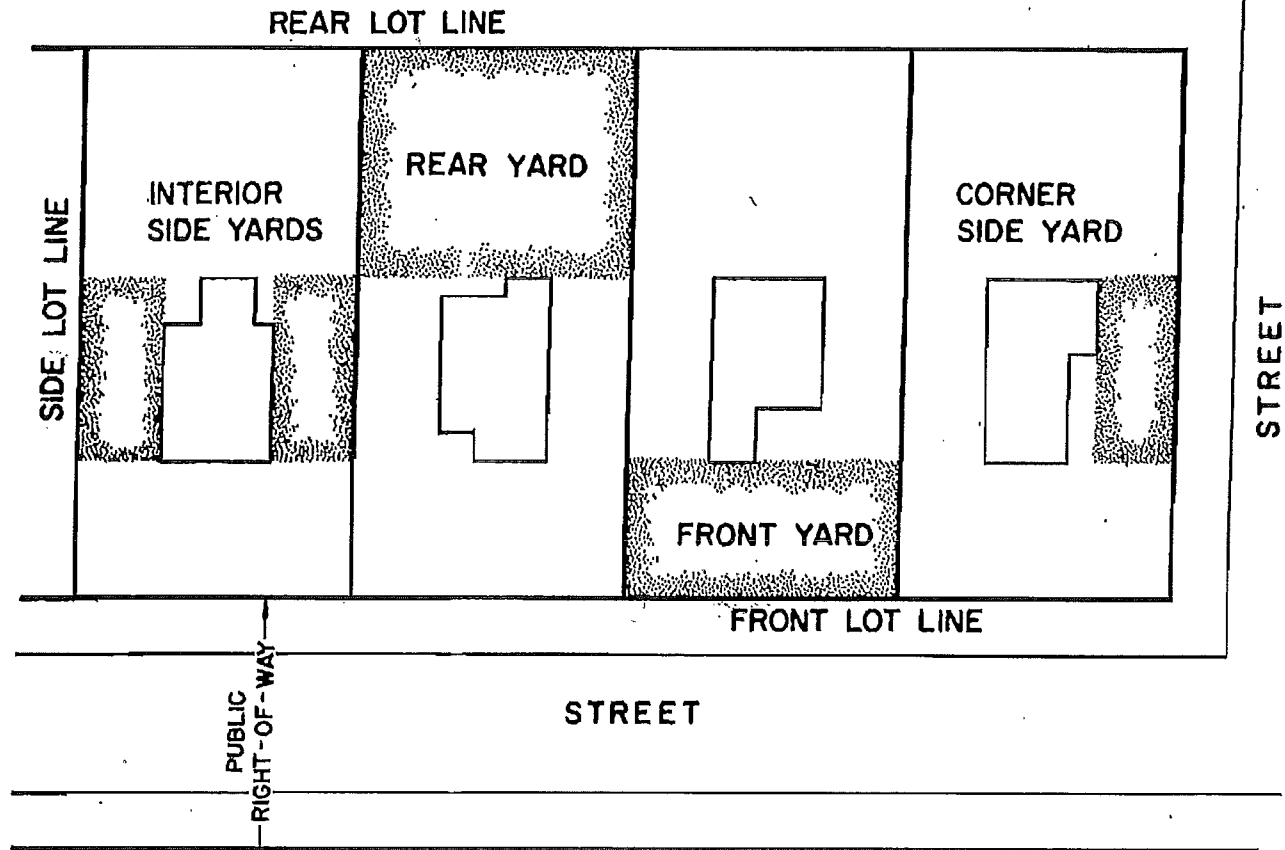

## TRANSITIONAL YARDS

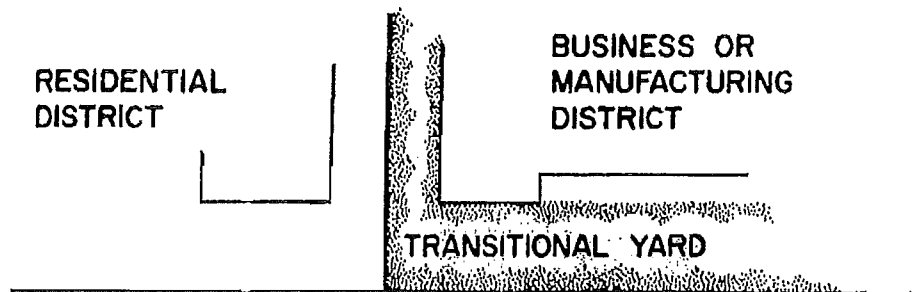

# SIGNS - TYPES

ADVERTISING DEVICE

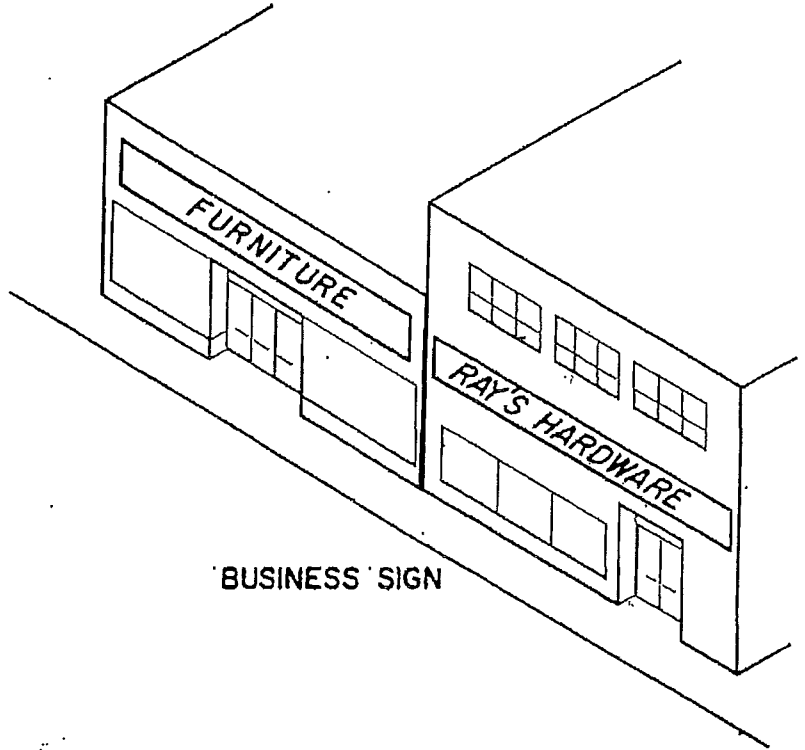
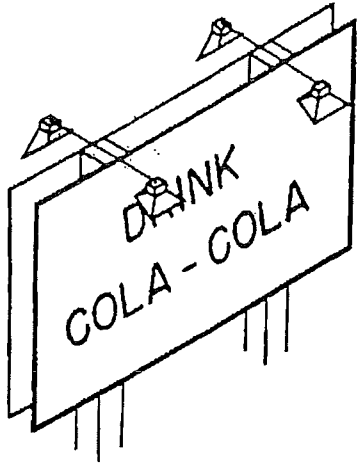

BUSINESS SIGN

DIRECTLY ILLUMINATED SIGN  
(OUTWARD GLARE)

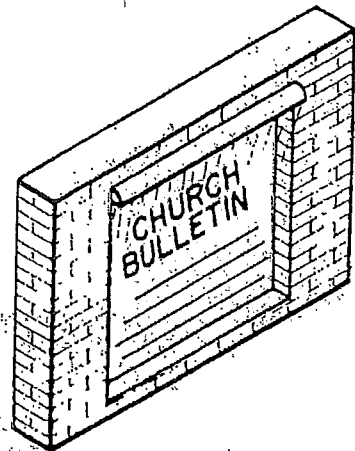
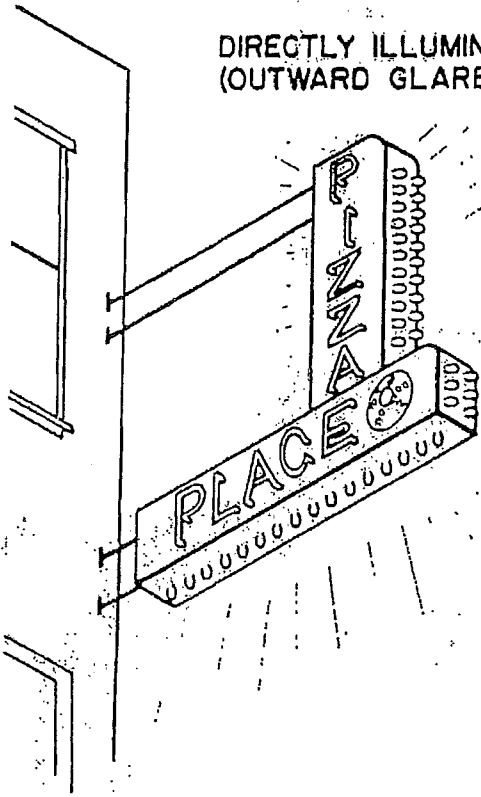

INDIRECTLY ILLUMINATED SIGN  
(MINIMUM LIGHT REFLECTION)

# MANUFACTURING PLANNED DEVELOPMENT

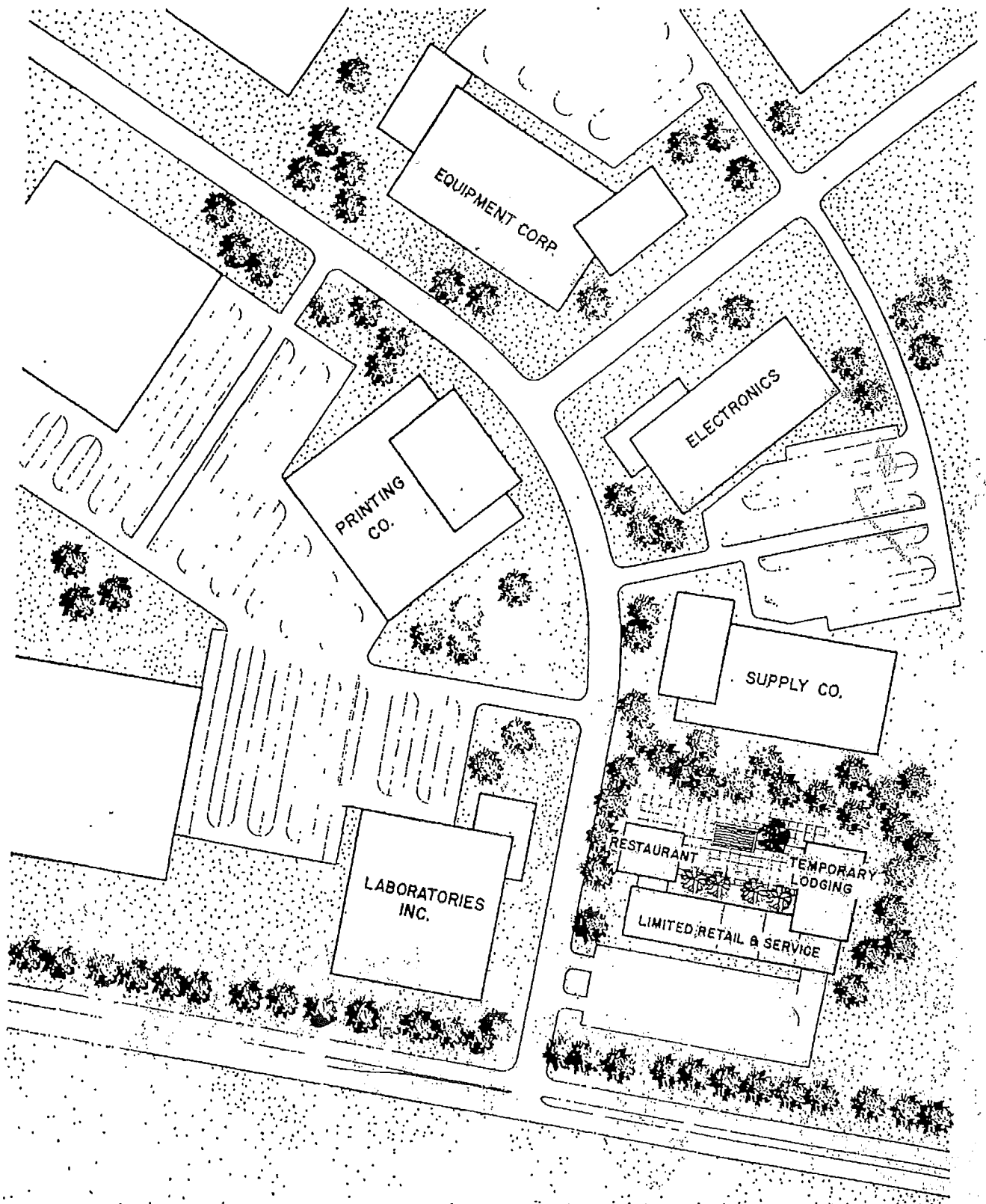

# BUILDINGS-PRINCIPAL AND ACCESSORY

R4 DISTRICT

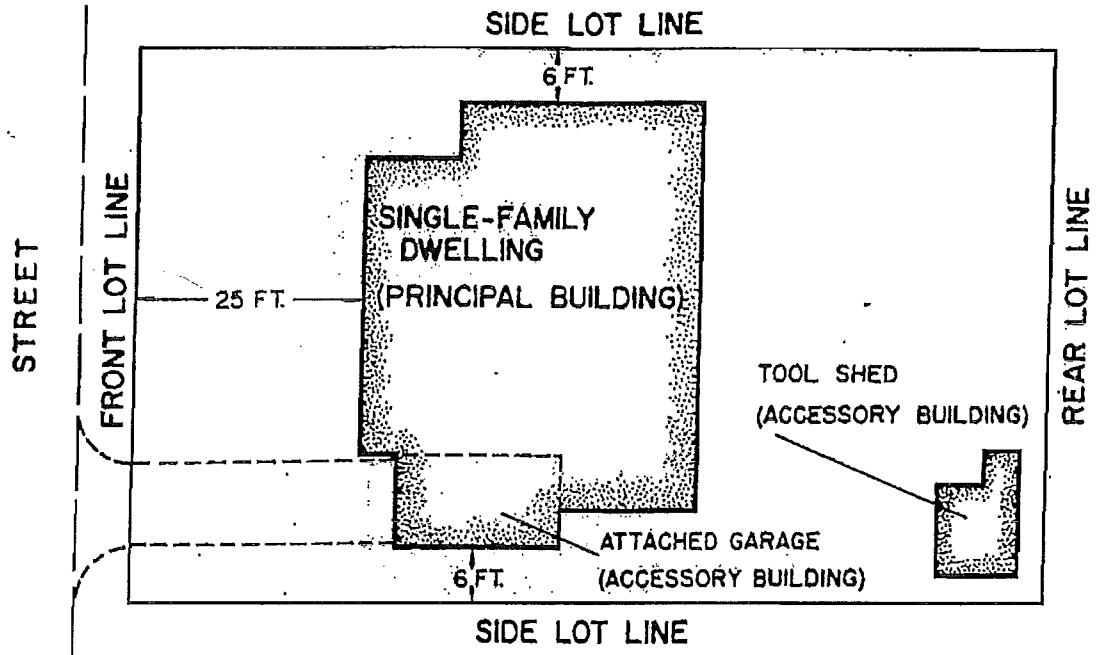

B2 DISTRICT

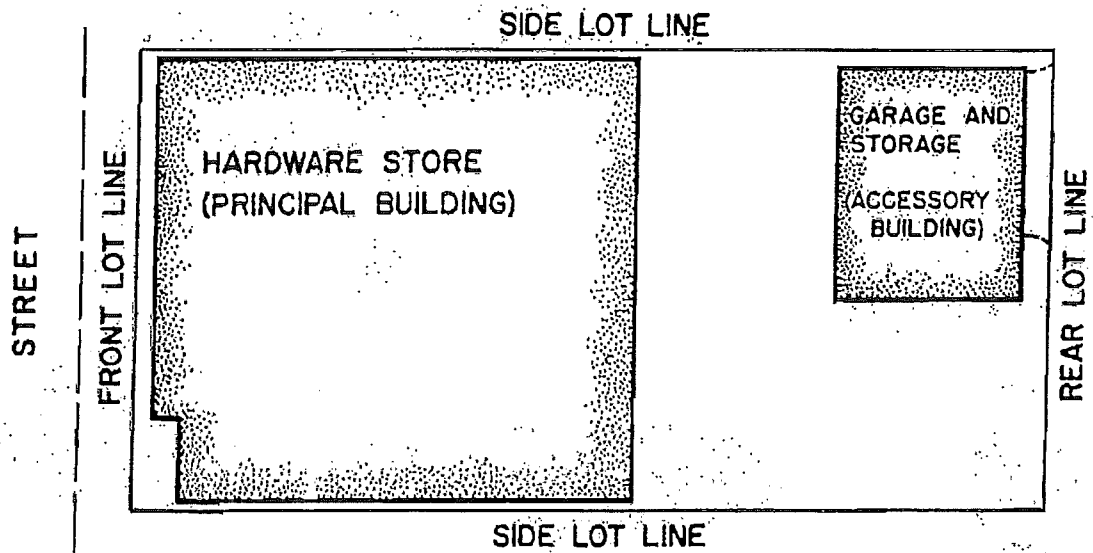



# BUSINESS PLANNED DEVELOPMENT

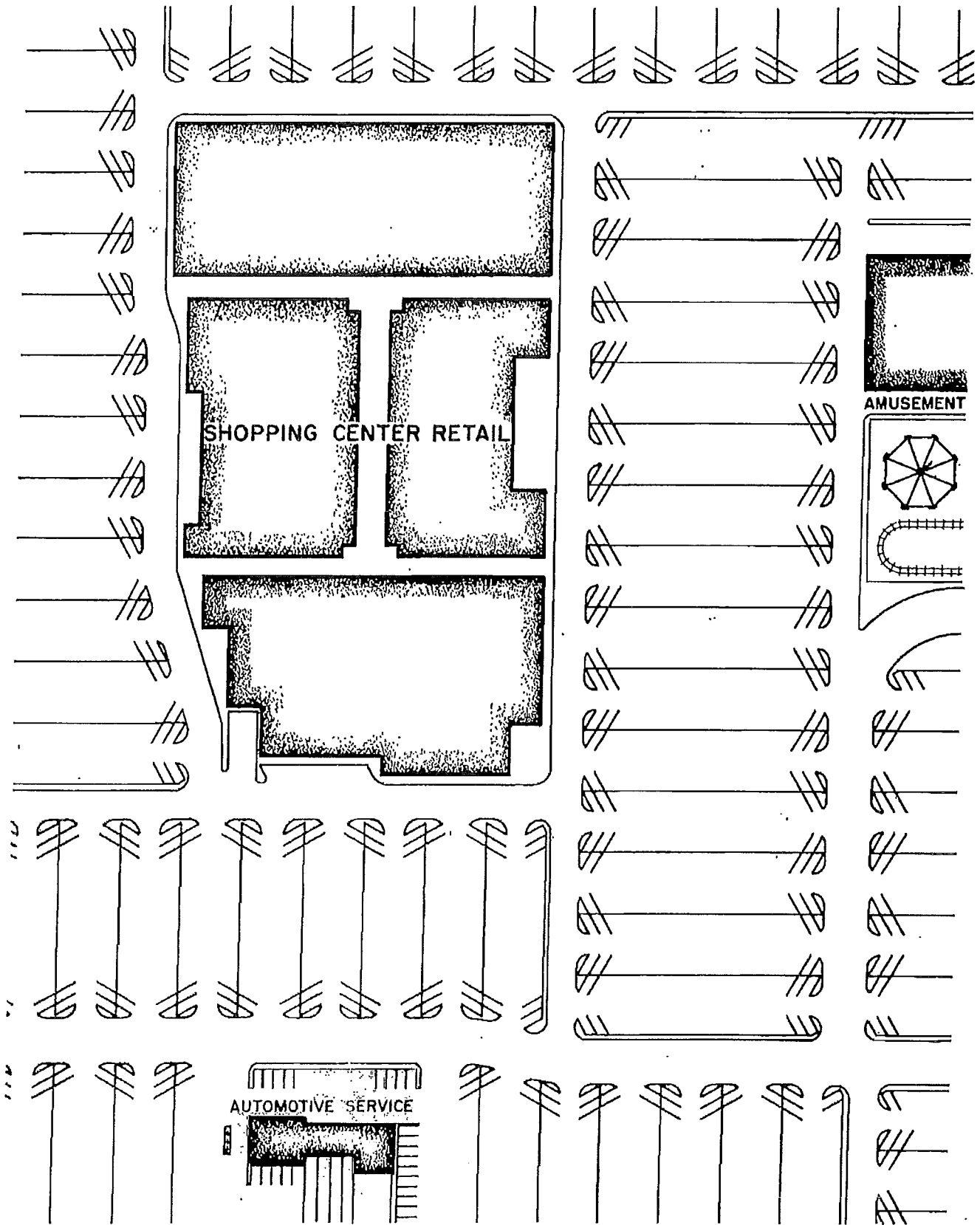

# FENCES, WALLS, AND OTHER STRUCTURES IN YARDS HEIGHT LIMITS -- ILLUSTRATED

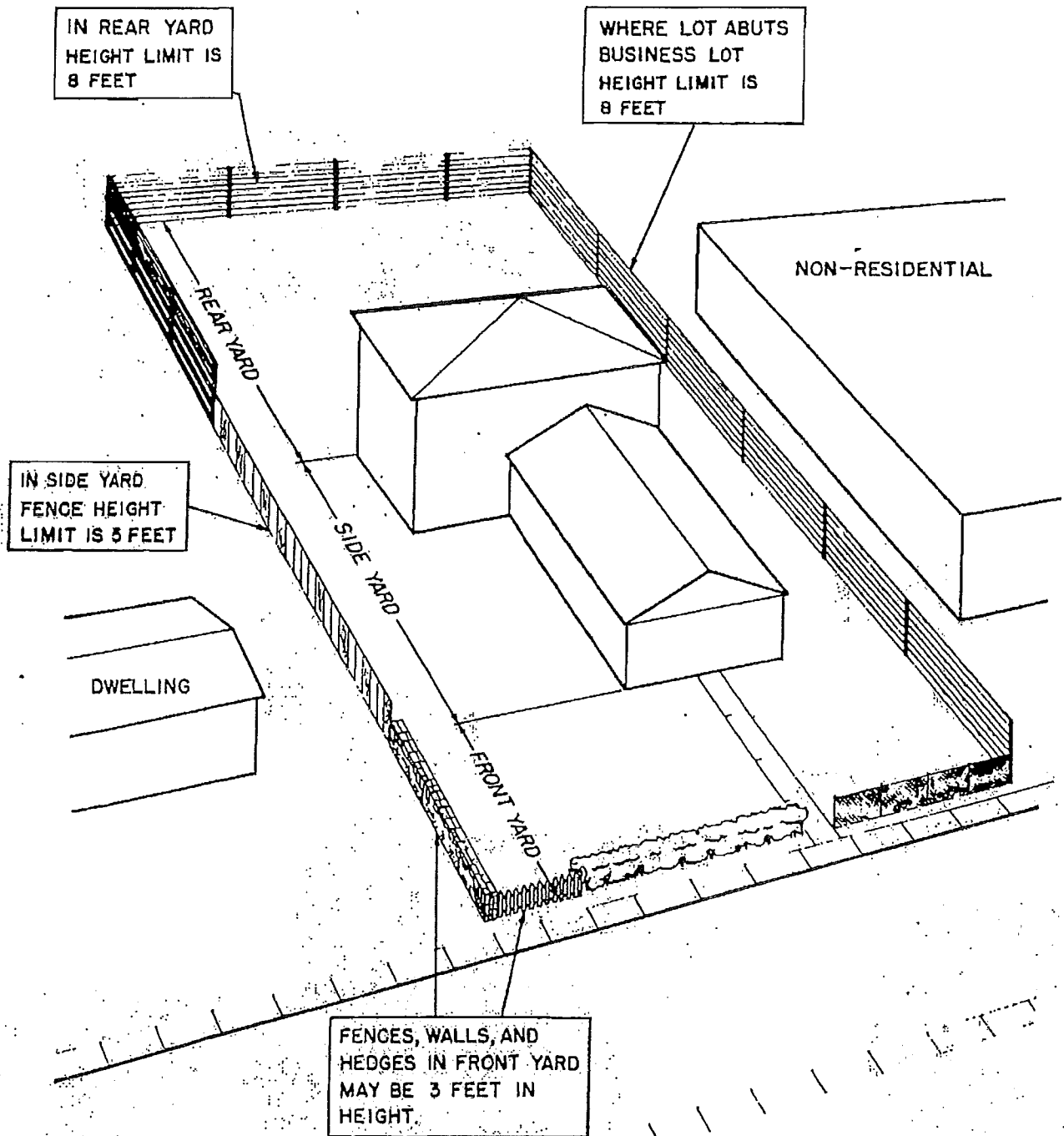

## EXAMPLE OF LOT TYPES

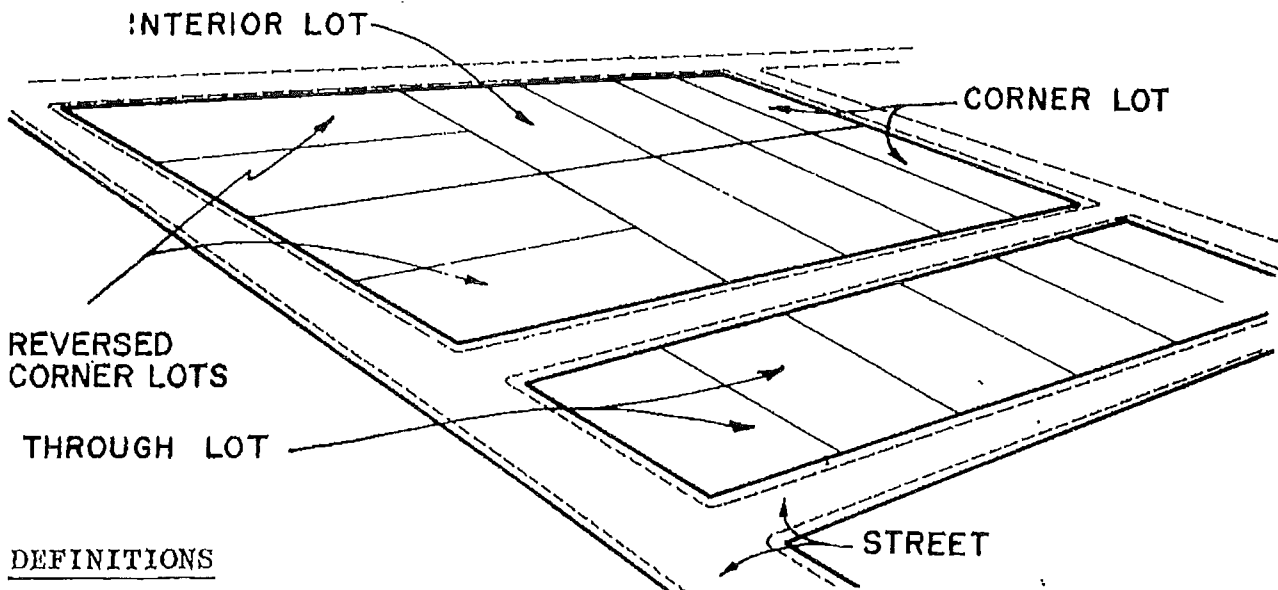
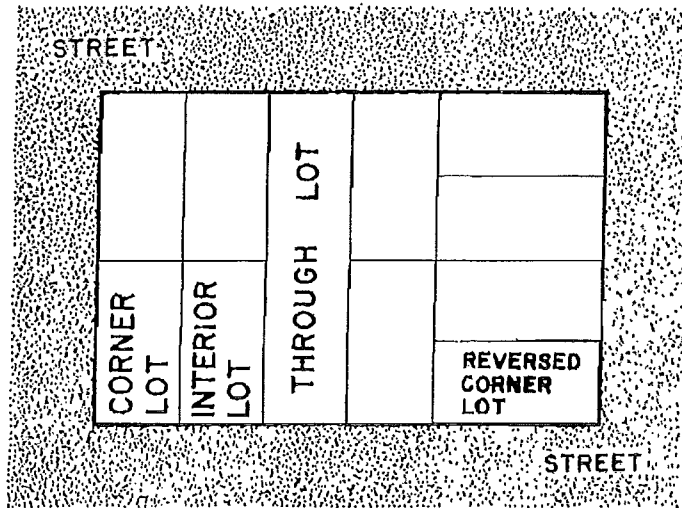

### DEFINITIONS

- CORNER LOT** is a lot abutting on two streets at their intersection, where the angle of intersection is not more than 135 degrees.
- REVERSED CORNER LOT** is a corner lot the street side lot line of which is substantially a continuation of the front lot line of the first lot to its rear.
- INTERIOR LOT** is a lot other than a corner or reversed corner lot.
- THROUGH LOT** is a lot having a pair of opposite lot lines along two more or less parallel public streets. On a through lot both street lines shall be deemed front lot lines.